

HANDBOOK  
**VALVES**

---

Ed. 2017

 **Castel**<sup>®</sup>  
Italian technology

# CHAPTER 4 ■ VALVES WITH BALL SHUTTER

## FOR REFRIGERATION PLANTS THAT USE HCFC, HFC OR HFO REFRIGERANTS



### APPLICATIONS

The 2-ways valves with ball shutter illustrated in this chapter are designed for installation on commercial refrigeration systems and on civil and industrial air conditioning plants that use the following refrigerant fluids:

- HCFC (R22)
- HFC (R134a, R404A, R407C, R410A, or R507)
- HFO and HFO/HFC mixtures (R1234ze, R448A, R449A, R450A, or R452A)

belonging to Group 2, as defined in Article 13, Chapter 1, Point (b) of Directive 2014/68/EU, with reference to EC Regulation No. 1272/2008.

Furthermore, the same valves with ball shutter, up to DN 25, that is models 6570/9 and 6571/11, can also be installed on systems using the following refrigeration fluids:

- HFC (R32)
- HFO (R1234yf)

classified as A2L in the ASHRAE 34-2013 standard, and belonging to Group 1, as defined in Article 13, Chapter 1, Point (a) of Directive 2014/68/EU, with reference to EC Regulation No. 1272/2008.

For specific applications with refrigerant fluids not listed above, please contact Castel Technical Department.

### CONSTRUCTION

The specific design of Castel valves with ball shutter:

- ensures the internal pressure equilibrium when the valve is closed,
- permits the two-directional flow of the refrigerant
- prevents any risk of ejection or explosion of the spindle.

The electric welding of the body and the seal gaskets, assembled on the spindle, ensure perfect hermetic seal of the valve.

Valves with ball shutter are available in the following two types:

- Valves in series 6570 - 6590 (full port) and in series 6571 - 6591 (reduced port) without access fitting.
- Valves in series 6570/A - 6590/A (full port) and in series 6571/A - 6591/A (reduced port) with access

fitting. These taps are equipped with mechanism 8395/A1 and cap 8392/A.

The main parts of the valves with ball shutter are made with the following materials:

- Hot forged brass EN 12420 – CW 617N for the body
- Hot forged brass EN 12420 – CW 617N, chromium plated, for the ball
- Copper pipe EN 12735-1 – Cu--DHP for solder connections
- Steel, with proper surface protection, for the spindle.
- Chloroprene rubber (CR) for outlet seal gaskets
- P.T.F.E. for the ball seat gaskets
- Hot forged brass EN 12420 – CW 617N for the protective cap of the spindle,

### INSTALLATION

The valves with ball shutter can be installed in all sections of a refrigerating system, in compliance with the limits and capacities indicated in Table 28. Table 27 shows the following functional characteristics of a valve with ball shutter.

- PS
- TS
- Kv factor

Brazing of the valves with ball shutter with solder connections should be carried out with care, using a low melting point filler material (min. 5% Ag). It is important to avoid direct contact between the torch flame and the valve body, which could be damaged and compromise the proper functioning of the entire valve.

### CERTIFICATIONS

Valves with ball shutter in series: 6570, 6571, 6590, and 6591 (with the exclusion of models 6570(M64A and greater and models 6571/24A and greater) have been approved by the American certification authority, Underwriters Laboratories Inc. These taps are **UL Listed** certified for the USA with file SA33319, in compliance with American standard UL 207.

TABLE 27: General characteristics of ball valves, UL approved

Catalogue Number		Connections		Ball Port Ø [mm]	Kv Factor [m³/h]	PS [bar]	TS [°C]		TA [°C]		Risk Category according to PED Recast	
without access fitting	with access fitting	ODS					min.	max.	min.	max.		
		Ø [in.]	Ø [mm]									
6570/M6	6570/M6A	–	6	10	0,8	45 (1)	-40	+150	-40	+50	Art. 4.3	
6570/2	6570/2A	1/4"	–									
6570/3	6570/3A	3/8"	–									
6570/M10	6570/M10A	–	10		3							
6570/M12	6570/M12A	–	12									
6570/4	6570/4A	1/2"	–		5							
6570/M15	6570/M15A	–	15	15	17							
6570/5	6570/5A	5/8"	16									
6570/M18	6570/M18A	–	18									
6570/6	6570/6A	3/4"	–									
6570/7	6570/7A	7/8"	22	19	29							
6570/M28	6570/M28A	–	28	25	51							
6570/9	6570/9A	1.1/8"	–	32	86							
6590/11	6590/11A	1.3/8"	35	38	117							
6590/13	6590/13A	1.5/8"	–	50	214							
6590/M42	6590/M42A	–	42	60	380							
6590/17	6590/17A	2.1/8"	54									
6570/M64 (2)	6570/M64A (2)	–	64	73	550							
–	6570/21A (2)	2.5/8"	–									
–	6570/24A (2)	3"	76									
–	6570/25A (2)	3.1/8"	80									
–	6570/28A (2)	3.1/2"	89									
–	6570/29A (2)	3.5/8"	92	82	710							
6571/5	–	5/8"	16	10	5	45 (1)	-40	+150	-40	+50	Art. 4.3	
6571/7		7/8"	22	15	17							
6571/M28		–	28	19	29							
6571/9		1.1/8"	–	25	51							
6571/11		1.3/8"	35	32	86							
6591/13		1.5/8"	–	38	117							
6591/M42		–	42	50	214							
6591/17		2.1/8"	54	60	380							
6591/M64		6591/M64A	–	64	50							214
6591/21		6591/21A	2.5/8"	–								
–	6571/24A (2)	3"	76	60	380							
–	6571/25A (2)	3.1/8"	80									
–	6571/28A (2)	3.1/2"	89	73	550							
–	6571/29A (2)	3.5/8"	92									
–	6571/33A (2)	4.1/8"	105	82	660							
–	6571/34A (2)	4.1/4"	108									

(1) : MWP = 500 psi for 6570/.. and 6590/.. - MWP = 435 psi for 6571/.. and 6591/.. according to UL approval  
 (2) : not UL approved

**TABLE 28: Refrigerant flow capacity of ball valves [kW]**

Catalogue Number		Liquid line												
without access fitting	with access fitting	R134a	R22	R32	R404A	R407C	R410A	R507	R1234yf	R1234ze	R448A	R449A	R450A	R452A
6570/M6	6570/M6A	13,6	14,6	20,1	9,5	13,8	13,7	9,2	10,1	12,0	12,5	12,6	12,7	9,7
6570/2	6570/2A													
6570/3	6570/3A	51	55	75	36	52	52	35	38	45	47	47	48	36
6570/M10	6570/M10A													
6570/M12	6570/M12A	85	92	126	60	86	86	58	63	75	78	79	80	61
6570/4	6570/4A													
6571/5	–													
6570/M15	6570/M15A	289	311	427	202	293	292	196	214	256	266	267	270	206
6570/5	6570/5A													
6570/M18	6570/M18A	289	311	427	202	293	292	196	214	256	266	267	270	206
6570/6	6570/6A													
6571/7	–													
6570/7	6570/7A	493	531	729	345	500	498	334	365	436	454	456	461	352
6571/M28	–													
6571/9	–													
6570/M28	6570/M28A	867	933	1282	607	879	876	587	642	767	798	802	811	619
6570/9	6570/9A													
6571/11	–													
6590/11	6590/11A	1462	1574		1023	1482	1477	989		1293	1346	1352	1368	1043
6591/13	–													
6591/M42	–													
6590/13	6590/13A	1989	2141		1392	2016	2009	1346		1760	1831	1839	1861	1419
6590/M42	6590/M42A													
6591/17	–													
6590/17	6590/17A	3638	3916		2547	3687	3674	2461		3219	3349	3364	3405	2596
6591/M64	6591/M64A													
6591/21	6591/21A													
6570/M64	6570/M64A	6460	6954		4522	6547	6525	4370		5715	5947	5974	6046	4609
	6571/24A													
	6571/25A													
	6570/24A	9350	10065		6545	9477	9444	6325		8272	8608	8646	8751	6672
	6570/25A													
	6571/28A													
	6571/29A													
	6570/28A	12070	12993		8449	12233	12191	8165		10678	11112	11161	11296	8612
	6570/29A													
	6571/33A	11220	12078		7854	11372	11332	7590		9926	10329	10375	10501	8006
	6571/34A													

Standard rating conditions according to AHRI Standard 760-2007

Continued

Condensing temperature	110 °F	(43,3 °C)	Evaporator outlet temperature	50 °F	(9,9 °C)
Liquid temperature	100 °F	(37,8 °C)	Evaporator superheating	10 °R	(5,5 °K)
Subcooling	10 °R	(5,5 °K)	Suction line temperature	65 °F	(18,3 °C)
Evaporating temperature	40 °F	(4,4 °C)	Suction superheating	15 °R	(8,4 °K)
			Discharge temperature	160 °F	(71,1 °C)

TABLE 28: Refrigerant flow capacity of ball valves [kW]

Catalogue Number		Suction line												
without access fitting	with access fitting	R134a	R22	R32	R404A	R407C	R410A	R507	R1234yf	R1234ze	R448A	R449A	R450A	R452A
6570/M6	6570/M6A	1,5	2,0	3,4	1,8	1,8	2,6	1,8	1,2	1,1	1,9	1,8	1,3	1,7
6570/2	6570/2A													
6570/3	6570/3A	5,5	7,7	12,8	6,6	6,8	9,9	6,7	4,4	4,3	7,2	6,6	4,8	6,3
6570/M10	6570/M10A													
6570/M12	6570/M12A	9,1	12,8	21,3	11,0	11,4	16,5	11,2	7,4	7,1	12,0	11,0	8,0	10,6
6570/4	6570/4A													
6571/5	–													
6570/M15	6570/M15A	31	43	72	37	39	56	38	25	24	41	37	27	36
6570/5	6570/5A													
6570/M18	6570/M18A													
6570/6	6570/6A													
6571/7	–													
6570/7	6570/7A	53	74	123	64	66	96	65	43	41	70	64	46	61
6571/M28	–													
6571/9	–													
6570/M28	6570/M28A	93	130	217	112	116	168	114	75	72	122	112	81	108
6570/9	6570/9A													
6571/11	–													
6590/11	6590/11A	157	219		189	195	284	192		122	206	189	137	181
6591/13	–													
6591/M42	–													
6590/13	6590/13A	213	298		257	266	386	261		166	281	257	186	247
6590/M42	6590/M42A													
6591/17	–													
6590/17	6590/17A	389	546		471	486	706	477		304	514	471	340	452
6591/M64	6591/M64A													
6591/21	6591/21A													
6570/M64	6570/M64A	692	969		836	863	1254	847		540	912	836	604	802
	6570/21A													
	6571/24A													
	6571/25A	1001	1403		1210	1249	1815	1227		781	1320	1210	875	1161
	6570/24A													
	6570/25A													
	6571/28A	1292	1811		1562	1612	2343	1583		1008	1704	1562	1129	1498
	6571/29A													
	6570/28A	1201	1683		1452	1498	2178	1472		937	1584	1452	1049	1393
	6570/29A													
	6571/33A													
	6571/34A													

Standard rating conditions according to AHRI Standard 760-2007

Continued

Condensing temperature	110 °F	(43,3 °C)	Evaporator outlet temperature	50 °F	(9,9 °C)
Liquid temperature	100 °F	(37,8 °C)	Evaporator superheating	10 °R	(5,5 °K)
Subcooling	10 °R	(5,5 °K)	Suction line temperature	65 °F	(18,3 °C)
Evaporating temperature	40 °F	(4,4 °C)	Suction superheating	15 °R	(8,4 °K)
			Discharge temperature	160 °F	(71,1 °C)

**TABLE 28: Refrigerant flow capacity of ball valves [kW]**

Catalogue Number		Hot Gas line													
without access fitting	with access fitting	R134a	R22	R32	R404A	R407C	R410A	R507	R1234yf	R1234ze	R448A	R449A	R450A	R452A	
6570/M6	6570/M6A	6,8	9,0	14,5	7,7	9,5	10,9	7,6	5,3	5,5	9,4	8,6	6,1	8,0	
6570/2	6570/2A														
6570/3	6570/3A	26	34	54	29	36	41	29	20	21	35	32	23	30	
6570/M10	6570/M10A														
6570/M12	6570/M12A	43	56	91	48	60	68	48	33	34	59	54	38	50	
6570/4	6570/4A														
6571/5	–														
6570/M15	6570/M15A	145	190	309	163	202	231	162	113	116	201	183	130	170	
6570/5	6570/5A														
6570/M18	6570/M18A														
6570/6	6570/6A														
6571/7	–	247	325	527	278	345	394	277	193	199	342	313	222	289	
6570/7	6570/7A														
6571/M28	–														
6571/9	–	434	571	926	490	607	694	487	339	349	602	550	390	509	
6570/M28	6570/M28A														
6570/9	6570/9A														
6571/11	–	731	963		826	1023	1170	820		589	1015	927	658	858	
6590/11	6590/11A														
6591/13	–														
6591/M42	–	995	1310		1123	1392	1591	1116		801	1381	1261	895	1168	
6590/13	6590/13A														
6590/M42	6590/M42A														
6591/17	–	1819	2397		2054	2547	2910	2042		1466	2525	2307	1637	2136	
6590/17	6590/17A														
6591/M64	6591/M64A														
6591/21	6591/21A	3230	4256		3648	4522	5168	3625		2603	4484	4096	2907	3792	
6570/M64	6570/M64A														
–	6571/24A														
–	6571/25A	4675	6160		5280	6545	7480	5247		3768	6490	5929	4208	5489	
–	6570/24A														
–	6570/25A														
–	6571/28A	6035	7952		6816	8449	9656	6773		4864	8378	7654	5432	7086	
–	6571/29A														
–	6570/28A	5610	7392		6336	7854	8976	6296		4521	7788	7115	5049	6587	
–	6570/29A														
–	6571/33A														
–	6571/34A														

Standard rating conditions according to AHRI Standard 760-2007

Condensing temperature	110 °F	(43,3 °C)	Evaporator outlet temperature	50 °F	(9,9 °C)
Liquid temperature	100 °F	(37,8 °C)	Evaporator superheating	10 °R	(5,5 °K)
Subcooling	10 °R	(5,5 °K)	Suction line temperature	65 °F	(18,3 °C)
Evaporating temperature	40 °F	(4,4 °C)	Suction superheating	15 °R	(8,4 °K)
			Discharge temperature	160 °F	(71,1 °C)

TABLE 29: Dimensions and weights of ball valves

Catalogue Number		Dimensions [mm]							Weight [g]					
		H	H <sub>1</sub>	H <sub>2</sub>	L	L <sub>1</sub>	L <sub>2</sub>	l		d				
6570/M6	6570/M6A	48	15	29	121	65	25	18	M4	198				
6570/2	6570/2A									201				
6570/3	6570/3A													
6570/M10	6570/M10A													
6570/M12	6570/M12A													
6570/4	6570/4A	55	19	32	139	73	30	25,5	M4	208				
6571/5	-									-	138	73,5	-	311
6570/M15	6570/M15A									360				
6570/5	6570/5A													
6570/M18	6570/M18A													
6570/6	6570/6A	-	175	90,5	-	570								
6571/7	-	70	23	34	175	94	40	30	M6	601				
6570/7	6570/7A									708				
6571/M28	-													
6571/9	-	79	27	37	204	109	45	30	M6	840				
6570/M28	6570/M28A									1518				
6570/9	6570/9A													
6571/11	-	117	37	45	210	112	43	30	M6	2470				
6590/11	6590/11A									2520				
6591/13	-													
6591/M42	-	127	44	45	239	126	48	30	M6	4360				
6590/13	6590/13A									4400				
6590/M42	6590/M42A													
6591/17	-	148	54	53	275	149	58	30	M6	6000				
6590/17	6590/17A									6240				
6591/M64	6591/M64A													
6591/21	6591/21A	150	55	57	343	186	68	75	M8	6410				
6570/M64	6570/M64A									6580				
-	6570/21A													
-	6571/24A													
-	6571/25A													
-	6570/24A	186,5	70	64	365,5	196,5	69	89	M8	10735				
-	6570/25A									10790				
-	6571/28A													
-	6571/29A													
-	6570/28A	195	75	68	373	197,5	70,5	75	M8	11012				
-	6570/29A									12789				
-	6571/33A													
-	6571/34A													
-	6571/34A													
-	6571/34A	405	213,5	86,5	405	213,5	86,5	75	M8	12807				
-	6570/29A									13223				
-	6571/33A													
-	6571/34A													
-	6571/34A													

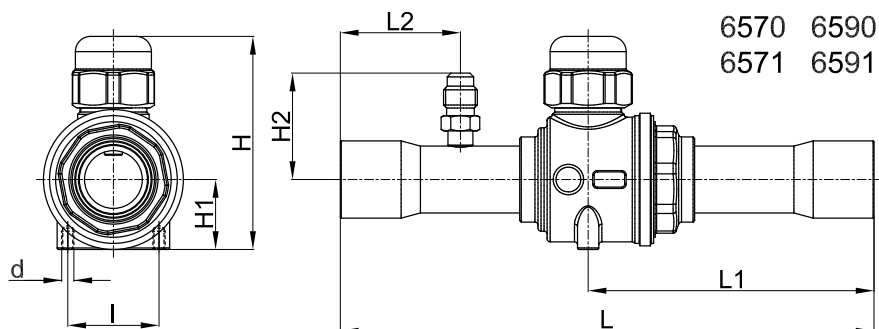

# CHAPTER 5

## VALVES WITH BALL SHUTTER

### FOR REFRIGERATION PLANTS THAT USE HC REFRIGERANTS



#### APPLICATIONS

The valves with ball shutter illustrated in this chapter have been developed by Castel for all those refrigeration applications that use the following HC refrigeration fluids: R290, R600, and R600a, belonging to Group 1, defined in Article 13, Chapter 1, Point (a) of Directive 2014/68/EU, with reference to EC Regulation No. 1272/2008.

**CAUTION! The valves with ball shutter illustrated in this chapter cannot be used with mineral oils or alkylbenzenes.**

#### CONSTRUCTION

The specific design of Castel valves with ball shutter:

- ensures the internal pressure equilibrium when the tap is closed,

- permits the two-directional flow of the refrigerant
  - prevents any risk of ejection or explosion of the spindle.
- The electric welding of the body and the seal gaskets, assembled on the spindle, ensure perfect hermetic seal of the valve. The valves with ball shutter in series 6570N are full port without charge access.

The main parts of the valves with ball shutter are made with the following materials:

- Hot forged brass EN 12420 – CW 617N for the body
- Hot forged brass EN 12420 – CW 617N, chromium plated, for the ball
- Copper pipe EN 12735-1 – Cu--DHP for solder connections
- Steel, with proper surface protection, for the spindle.
- Hydrogenated nitrile butadiene rubber (HNBR) for outlet seal gaskets.
- P.T.F.E. for the ball seat gaskets
- Hot forged brass EN 12420 – CW 617N for the protective cap of the spindle

#### INSTALLATION

The valves with ball shutter can be installed in all sections of a refrigerating system, in compliance with the limits and capacities indicated in Table 31. Table 30 shows the following functional characteristics of a valve with ball shutter.

- PS
- TS
- Kv factor

Brazing of the valves with ball shutter with solder connections should be carried out with care, using a low melting point filler material (min. 5% Ag). It is important to avoid direct contact between the torch flame and the valve body, which could be damaged and compromise the proper functioning of the entire valve.

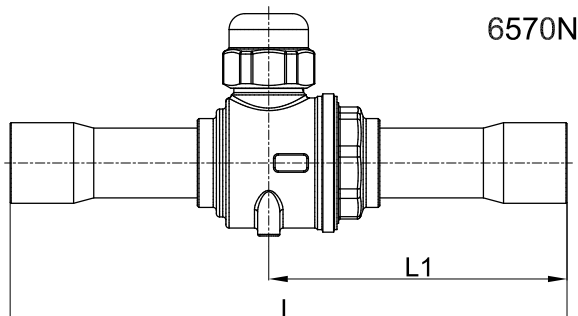
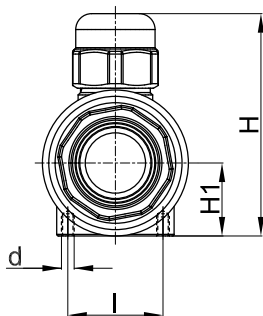



**TABLE 30: General characteristics of ball valves for HC refrigerants**

Catalogue Number	Connections		Ball Port Ø [mm]	Kv Factor [m³/h]	PS [bar]	TS [°C]		TA [°C]		Risk Category according to PED Recast
	ODS					min.	max.	min.	max.	
	Ø [in.]	Ø [mm]								
6570N/M6	–	6	10	0,8	45	-40	+150	-40	+50	Art. 4.3
6570N/2	1/4"	–								
6570N/3	3/8"	–		5						
6570N/M10	–	10								
6570N/M12	–	12								
6570N/4	1/2"	–	15	17						
6570N/5	5/8"	16								
6570N/M18	–	18								
6570N/6	3/4"	–								
6570N/7	7/8"	22								
6570N/M28	–	28	25	51						
6570N/9	1.1/8"	–								

**TABLE 31: Refrigerant flow capacity of ball valves for HC refrigerants [kW]**

Catalogue Number	Liquid line			Suction line			Hot Gas line		
	R290	R600	R600a	R290	R600	R600a	R290	R600	R600a
6570N/M6	16,3	19,1	17,0	2,4	1,0	1,3	10,2	5,2	6,0
6570N/2									
6570N/3	61	72	64	9,2	3,9	4,7	38	19	22
6570N/M10									
6570N/M12	102	120	106	15,3	6,5	7,9	64	32	37
6570N/4									
6570N/5	346	406	360	52	22	27	217	110	126
6570N/M18									
6570N/6									
6570N/7	591	693	615	88	37	46	370	187	216
6570N/M28	1039	1219	1081	156	66	81	651	329	379
6570N/9									

Standard rating conditions according to AHRI Standard 760-2007

Condensing temperature	110 °F	(43,3 °C)	Evaporator outlet temperature	50 °F	(9,9 °C)
Liquid temperature	100 °F	(37,8 °C)	Evaporator superheating	10 °R	(5,5 °K)
Subcooling	10 °R	(5,5 °K)	Suction line temperature	65 °F	(18,3 °C)
Evaporating temperature	40 °F	(4,4 °C)	Suction superheating	15 °R	(8,4 °K)
			Discharge temperature	160 °F	(71,1 °C)

**TABLE 32: Dimensions and weights of ball valves for HC refrigerants**

Catalogue Number	Dimensions [mm]						Weight [g]
	H	H <sub>1</sub>	L	L <sub>1</sub>	l	d	
6570N/M6	48	15	121	65	18	M4	198
6570N/2							
6570N/3							201
6570N/M10							
6570N/M12							
6570N/4	55	19	139	73	25,5		311
6570N/5							
6570N/M18							
6570N/6	70	23	175	94	30		570
6570N/7							
6570N/M28						79	
6570N/9							

# CHAPTER 6

## VALVES WITH BALL SHUTTER

### FOR REFRIGERATION PLANTS THAT USE THE R744 REFRIGERANT



#### APPLICATIONS

The valves with ball shutter illustrated in this chapter have been developed by Castel for all the applications that use the sub-critical or trans-critical R744 refrigeration fluid belonging to Group 2, defined in Article 13, Chapter 1, Point (b) of Directive 2014/68/EU, with reference to EC Regulation No. 1272/2008.

The valves with ball shutter for plants that operate using refrigerant fluid R744 are the following:

- Valves in series 6570EL and 6590EL with PS = 60 bar, equipped with copper connections for sub-critical plants.
- Valves in series 6570E and 6590E with PS = 80 bar, equipped with copper connections for trans-critical plants, low and medium pressure sides.
- Valves in series 6577E and 6597E with PS = 120 bar equipped with reinforced copper connections (K65) for trans-critical plants, high pressure side.
- Valves in series 6578E and 6598E with PS = 140 bar equipped with reinforced stainless steel connections for trans-critical plants, high-pressure side.

**CAUTION! The valves with ball shutter in this chapter cannot be used with other refrigerant fluids.**

#### CONSTRUCTION

The specific design of Castel valves with ball shutter:

- ensures the internal pressure equilibrium when the tap is closed,
- permits the two-directional flow of the refrigerant
- prevents any risk of ejection or explosion of the spindle.

The electric welding of the body and the seal gaskets, assembled on the spindle, ensure perfect hermetic seal of the valve. Valves with ball shutter in series: 6570EL, 6590EL, 6570E, 6590E, 6577E, 6597E, 6578E, 6598E are full port with no charge access.

The main parts of the valves with ball shutter are made with the following materials:

- Hot forged brass EN 12420 – CW 617N for the body

- Hot forged brass EN 12420 – CW 617N, chromium plated, for the ball
- Steel, with proper surface protection, for the spindle.
- Ethylene propylene rubber (EPDM) for outlet seal gaskets
- PTFE for the ball seat gaskets
- Hot forged brass EN 12420 – CW 617N for the protective cap of the spindle
- Copper pipe EN 12735-1 – Cu-DHP for solder connections in series 6570EL, 6590EL, 6570E and 6590E.
- Copper pipe EN 12735-1 – CuFe2P (K65) for welded connections in series 6577E, and 6597E
- Stainless steel pipe AISI 304 for welded connections in series 6578E and 6598E.

#### INSTALLATION

The valves with ball shutter can be installed in all sections of a refrigerating system, in compliance with the limits and capacities indicated in Table 34. Table 33 shows the following functional characteristics of a valve with ball shutter.

- PS
- TS
- Kv factor

**Copper connections:** The brazing of valves with solder connections should be carried out with care, using a low melting point filler material (min.5 Ag). It is important to avoid direct contact between the torch flame and the valve body, which could be damaged and compromise the proper functioning of the entire valve.

**Steel connectors:** TIG welding recommended, to be performed as quickly as possible according to the method shown in the product instruction sheet. The connection material is AISI 304: it is only possible to use AISI 308 filler material if welding to pipes made from the same type of material. For pipes made from other materials, please contact your welding supplies supplier.

**TABLE 33: General characteristics of ball valves for R744**

Catalogue Number	Connections			Ball Port Ø [mm]	Kv Factor [m³/h]	PS [bar]	TS [°C]		TA [°C]		Risk Category according to PED Recast								
	ODS		W				min.	max.	min.	max.									
	Ø [in.]	Ø [mm]	Ø [mm]																
6570EL/M6	-	-	-	10	0,8	60	-40	+150	-40	+50	Art. 4.3								
6570EL/2	1/4"	1/4"			3														
6570EL/3	3/8"	3/8"			5														
6570EL/M10	-	-			15							17							
6570EL/M12	-	-										19	29						
6570EL/4	1/2"	1/2"		25	51														
6570EL/5	5/8"	5/8"		32	86														
6570EL/M18	-	-		38	117														
6570EL/6	3/4"	3/4"			50							214							
6570EL/7	7/8"	7/8"		-	10							0,8	80	-40	+150	-40	+50	Art. 4.3	
6570EL/M28	-	-										3							
6570EL/9	1.1/8"	1.1/8"										5							
6590EL/11	-	-										15							17
6590EL/13	1/4"	1/4"																	19
6590EL/M42	3/8"	3/8"			25							51							
6590EL/17	-	-			32							86							
6570E/M6	-	6			38							117							
6570E/2	1/4"	-	50			214													
6570E/3	3/8"	-	-		10	0,8	80	-40	+150	-40	+50	Art. 4.3							
6570E/M10	-	10				3													
6570E/M12	-	12				5													
6570E/4	1/2"	-				15													17
6570E/5	5/8"	16																	19
6570E/M18	-	18			25	51													
6570E/6	3/4"	-			32	86													
6570E/7	7/8"	22			38	117													
6570E/M28	-	28		50		214													
6570E/9	1.1/8"	-		-	10	0,8							80	-40	+150	-40	+50	Art. 4.3	
6590E/11	1.3/8"	35				3													
6590E/13	1.5/8"	-				5													
6590E/M42	-	42				15													17
6590E/17	2.1/8"	54																	19
					25	51													
					32	86													
					38	117													
			50			214													

Continued

**TABLE 33: General characteristics of ball valves for R744**

Catalogue Number	Connections			Ball Port Ø [mm]	Kv Factor [m³/h]	PS [bar]	TS [°C]		TA [°C]		Risk Category according to PED Recast	
	ODS		W				min.	max.	min.	max.		
	Ø [in.]	Ø [mm]	Ø [mm]									
6577E/2	1/4"	–	–	10	0,8	120	-40	+150	-40	+50	Art. 4.3	
6577E/3	3/8"	–			3							
6577E/4	1/2"	–			5							
6577E/5	5/8"	16		15	17							
6577E/6	3/4"	–										
6597E/7	7/8"	22		19	29							
6597E/9	1.1/8"	–		25	51							
6597E/11	1.3/8"	35		32	86							
6597E/13	1.5/8"	–		38	117							
6597E/17	2.1/8"	54		50	214							I
6578E/M6	–	–	6	10	0,8	140	-40	+150	-40	+50	Art. 4.3	
6578E/M10			10		3							
6578E/M12			12		5							
6578E/M16			16	15	17							
6578E/M18			18									
6598E/M22			22	19	29							
6598E/M28			28	25	51							
6598E/M35			33,4	32	86							
6598E/M42			42,2	38	117							I

**TABLE 34: Refrigerant flow capacity of ball valves for R744 [kW]**

Catalogue Number	Subcritical system			Transcritical system		
	Liquid line	Suction line	Hot gas line	Gas cooler line	Suction line	Hot gas line
6570EL/M6	21	4,2	16			
6570EL/2						
6570EL/3	80	16	61			
6570EL/M10						
6570EL/M12	134	27	101			
6570EL/4						
6570EL/5	456	90	343			
6570EL/M18						
6570EL/6						
6570EL/7	777	154	585			
6570EL/M28	1367	270	1029			
6570EL/9						
6590EL/11	2305	456	1735			
6590EL/13	3136	620	2361			
6590EL/M42						
6590EL/17	5735	1134	4319			

Standard rating conditions according to AHRI Standard 760-2007 for subcritical system

Condensing temperature	30 °F (- 1,2 °C)	Evaporator superheating	10 °R (5,5 °K)
Liquid temperature	20 °F (- 6,7 °C)	Suction line temperature	- 5 °F (-15 °C)
Subcooling	10 °R (5,5 °K)	Suction superheating	15 °R (8,4 °K)
Evaporating temperature	- 20 °F (- 28,9 °C)	Discharge temperature	80 °F (26,6 °C)
Evaporator outlet temperature	- 10 °F (- 23,4 °C)		

Continued

Standard rating conditions according to AHRI Standard 760-2007 for transcritical system

Gas-cooler outlet temperature	95 °F (35 °C)	Suction line temperature	32 °F (0 °C)
Evaporating temperature	14 °F (- 10 °C)	Suction superheating	9 °R (5 °K)
Evaporator outlet temperature	23 °F (- 5 °C)	Discharge temperature	212 °F (110 °C)
Evaporator superheating	9 °R (5 °K)		

**TABLE 34: Refrigerant flow capacity of ball valves for R744 [kW]**

Catalogue Number	Subcritical system			Transcritical system		
	Liquid line	Suction line	Hot gas line	Gas cooler line	Suction line	Hot gas line
6570E/M6	21	4,2	16		3,7	
6570E/2						
6570E/3	80	16	61		14	
6570E/M10						
6570E/M12	134	27	101		23	
6570E/4						
6570E/5	456	90	343		79	
6570E/M18						
6570E/6						
6570E/7	777	154	585		134	
6570E/M28	1367	270	1029		236	
6570E/9						
6590E/11	2305	456	1735		398	
6590E/13	3136	620	2361		542	
6590E/M42						
6590E/17	5735	1134	4319		991	
6577E/2				21	3,7	15
6577E/3				79	14	56
6577E/4				131	23	93
6577E/5				447	79	318
6577E/6						
6597E/7				762	134	542
6597E/9				1340	236	953
6597E/11				2259	398	1607
6597E/13				3074	542	2187
6597E/17				5622	991	4000
6578E/M6				21	3,7	15
6578E/M10				79	14	56
6578E/M12				131	23	93
6578E/M16				447	79	318
6578E/M18						
6598E/M22				762	134	542
6598E/M28				1340	236	953
6598E/M35				2259	398	1607
6598E/M42				3074	542	2187

Standard rating conditions according to AHRI Standard 760-2007 for subcritical system

Condensing temperature	30 °F	(- 1,2 °C)	Evaporator superheating	10 °R	(5,5 °K)
Liquid temperature	20 °F	(- 6,7 °C)	Suction line temperature	- 5 °F	(-15 °C)
Subcooling	10 °R	(5,5 °K)	Suction superheating	15 °R	(8,4 °K)
Evaporating temperature	- 20 °F	(- 28,9 °C)	Discharge temperature	80 °F	(26,6 °C)
Evaporator outlet temperature	- 10 °F	(- 23,4 °C)			

Standard rating conditions according to AHRI Standard 760-2007 for transcritical system

Gas-cooler outlet temperature	95 °F	(35 °C)	Suction line temperature	32 °F	(0 °C)
Evaporating temperature	14 °F	(- 10 °C)	Suction superheating	9 °R	(5 °K)
Evaporator outlet temperature	23 °F	(- 5 °C)	Discharge temperature	212 °F	(110 °C)
Evaporator superheating	9 °R	(5 °K)			

TABLE 35: Dimensions and weights of ball valves for R744

Catalogue Number	Dimensions [mm]						Weight [g]	
	H	H <sub>1</sub>	L	L <sub>1</sub>	l	d		
6570EL/M6	48	15	121	65	18	M4	216	
6570EL/2								
6570EL/3								
6570EL/M10								
6570EL/M12								
6570EL/4								
6570EL/5	55	19	139	73	25,5		333	
6570EL/M18								
6570EL/6								
6570EL/7	70	23	175	94	30		M6	610
6570EL/M28	79	27	204	109		834		
6570EL/9								
6590EL/11	108	37	210	112		M6		1421
6590EL/13	120	44	239	126				2695
6590EL/M42								
6590EL/17	153	54	275	149	4260			
6570E/M6	48	15	121	65	18	M4	216	
6570E/2								
6570E/3								
6570E/M10								
6570E/M12								
6570E/4								
6570E/5	55	19	139	73	25,5		333	
6570E/M18								
6570E/6								
6570E/7	70	23	175	94	30		M4	610
6570E/M28	79	27	204	109		834		
6570E/9								
6590E/11	117	37	210	112		M6		1421
6590E/13	127	44	239	126				2695
6590E/M42								
6590E/17	148	54	275	149	4260			

Continued

TABLE 35: Dimensions and weights of ball valves for R744

Catalogue Number	Dimensions [mm]						Weight [g]
	H	H <sub>1</sub>	L	L <sub>1</sub>	l	d	
6577E/2	47	15	115	65	18	M4	216
6577E/3			122				
6577E/4			120				
6577E/5	54	19	126	70	25,5	M4	333
6577E/6			126				
6597E/7	80	28	175	93	18	M5	780
6597E/9	86	30	207	110	30	M6	1092
6597E/11	108	37	210	112			1734
6597E/13	120	44	239	126			2682
6597E/17	153	54	275	149			4236
6578E/M6	47	15	117	66	18	M4	216
6578E/M10			123				
6578E/M12			121				
6578E/M16	54	19	142	74	25,5	M4	333
6578E/M18			139				
6598E/M22	80	28	175	93	18	M5	770
6598E/M28	86	30	207	110	30	M6	1092
6598E/M35	108	37	210	112			1760
6598E/M42	120	44	239	126			2668

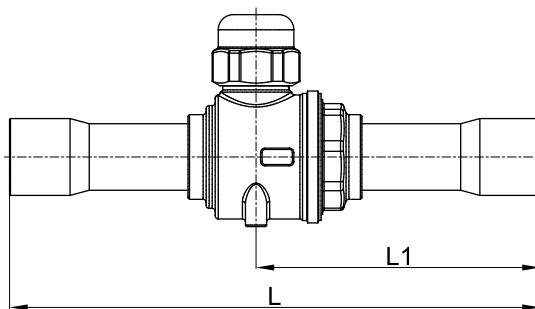
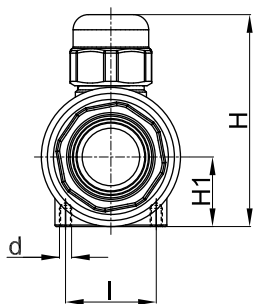

6570EL 6590EL  
6570E 6590E  
6577E 6597E

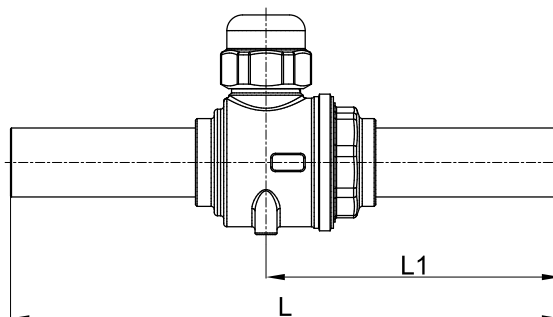
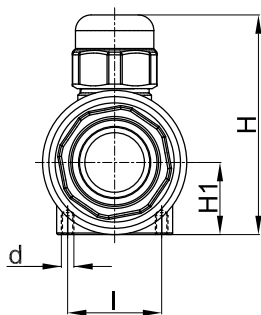

6578E  
6598E

[www.castel.it](http://www.castel.it)



ed. 002-VR-ENG

Castel can accept no responsibility for any errors or changes in the catalogues, handbooks, brochures and other printed material. Castel reserves the right to make changes and improvements to its products without notice. All trademarks mentioned are the property of their respective owners.

The name and Castel logotype are registered trademarks of Castel Srl.  
All rights reserved.

Castel Srl - Via Provinciale 2-4 - 20060 Pessano con Bornago - MI