

INT69 TML® Diagnose

INT69 TML® Diagnose

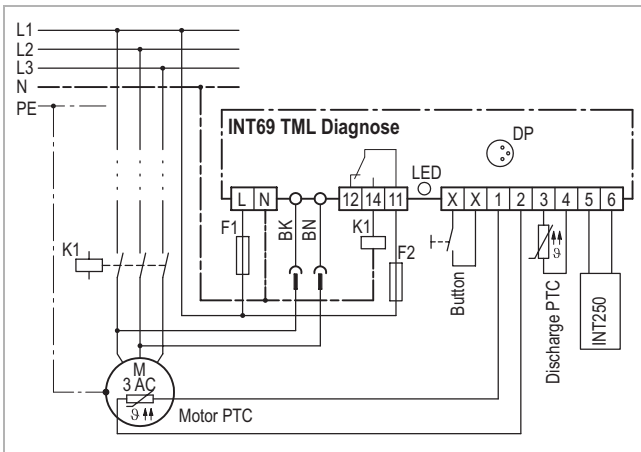

INT69 TML Diagnose



Wiring diagram

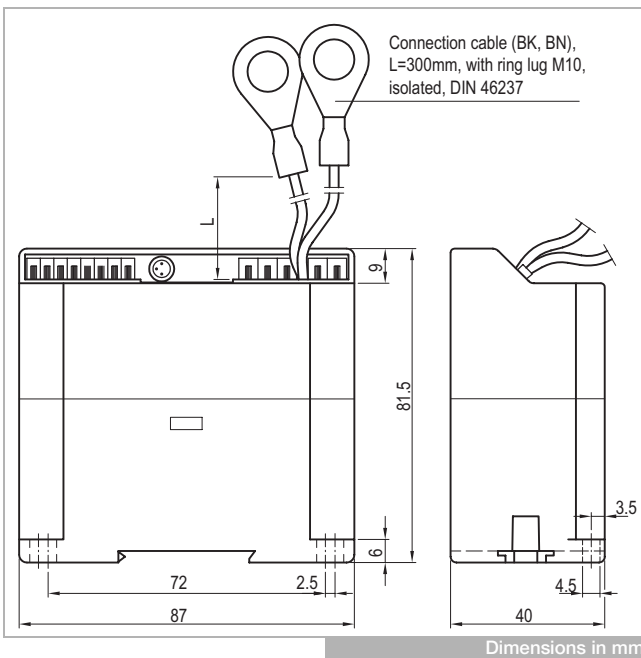

Dimensions in mm

Application

The compressor protection INT69 TML Diagnosis is a further development of the reliable KRIWAN motor protectors. Additional inputs for the discharge gas sensor and INT250 oil differential pressure switch as well as supplementary flexible-response protective functions help to improve the availability and extend the service life of a refrigeration system.

The INT69 TML Diagnosis automatically saves operational and error data in a non-volatile memory. This data can be retrieved on a PC and analysed for diagnosis. The full scope of the diagnosis is achieved by using a KRIWAN-specific AMS sensor.

This motor protector is mainly employed on medium and large semi-thermal piston compressors with oil pumps.

Functional description

The temperature monitoring of the motor winding is done with two evaluation processes:

- **Static:** Switch-off is immediate if the nominal response temperature of the built-in AMS or PTC sensors is reached.
- **Dynamic:** If the temperature increases unusually quickly, the motor is switched off immediately even if the temperature is still far below the nominal response temperature. This prevents excess temperatures from occurring.

The discharge gas temperature is evaluated statically.

A short circuit at an AMS or PTC input also leads to a switch-off. A short cycling leads to a reset delay. If no discharge gas sensor is installed, a 100 ohm resistor has to be installed at the input.

After cooldown or elimination of the error and a subsequent reset delay, the compressor can be restarted; restarting after locking only after reset.

Connecting an INT250 allows the differential pressure of the oil pump to be monitored. After every power reset, the compressor is only released once the INT250 is screwed in properly. After the compressor starts up, the differential pressure monitoring is active after the starting transition time of 5 seconds has elapsed. Fluctuations in the differential pressure are taken into account by an extension of the switch-off times (time integration). A missing differential pressure leads to a locked switch-off after 90 seconds. This lock can be reset 90 seconds after the switch-off at the earliest.

Prevailing differential pressure with compressor at a standstill will trigger a locked switch off after 5 seconds. This detection starts 10s after compressor stop.

Short circuit or open circuit at input for the INT250 lead to a switch-off. If no INT250 is used, the input of the motor protector can be deactivated by connecting a 10kOhm resistor and then performing a network restart.

For operation in the specified manner, the supply voltage has to be on permanently on the INT69 TML Diagnosis.

The built-in LED signals the current status of the motor protector (see flash code).

The mounting, maintenance and operation are to be carried out by an electrician. The valid European and national standards for connecting electrical equipment and cooling installations have to be observed. Connected sensors and connection lines that extend from the terminal box have to feature at least a basic insulation.

The electric circuit in which the sensor is located does not feature any safe electrical isolation from electric circuits with dangerous voltages, but is only separated by a basic insulation.

See back side for further specifications

INT69 TML® Diagnose

INT69 TML® Diagnose

Flash code

The KRIWAN flash code allows for a quick and easy status display and troubleshooting.

The flash code consists of a cyclical red and orange flash sequence. The current status can be determined from the number of pulsing flashes.

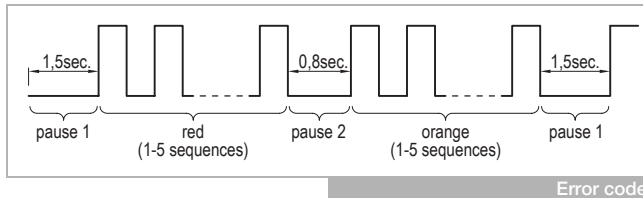

Overview flash code

Green lit	Compressor operational
Green flashing	Compressor running
Red/Orange flashing	Error, compressor is switched off; for description see table below

1st flashing sequence (LED red)	2nd flashing sequence (LED orange)	Description
1	1	Motor temperature: Static switch-off, Permissible winding temperature exceeded
	2	Motor temperature: Dynamic switch-off, Temperature rise in the motor winding unusually fast
	3	Motor temperature: Reset delay after static switch-off
	4	Motor temperature: Sensor input detected open circuit or short circuit
	5	Motor temperature: Reset delay after dynamic switch-off
3	5	General: Reset delay after "General" error
4	1	Oil: Differential pressure too low
	3	Oil: Reset delay after "Oil" error
	4	Oil: Sensor incorrectly connected
	5	Oil: Sensor input detected open circuit or short circuit
5	1	Permissible discharge gas temperature exceeded
	2	Reset delay after discharge gas error
	3	Discharge gas sensor input detected open circuit or short circuit

Technical specifications

Supply voltage	AC 50/60Hz 115-230V ±10% 3VA
Permitted ambient temperature	-30...+70°C
Temperature measuring circuits	
- Type	1-2 AMS sensors in series alternative 1-9 PTC acc. to DIN 44081, DIN 44082 in series <1.8kΩ
- R _{25,total}	4.5kΩ ±20%
- R _{trip, static}	2.75kΩ ±20%
- R _{reset}	30m
- Max. length connection line	
Short circuit monitoring system PTC and input INT250	Typically <30Ω
Input, operating recognition motor	
- Lower limit	AC 100V at 20Hz to 175V at 90Hz
- Upper limit	AC 690V ±15%
Operation with frequency converters	Suitable
Switching frequency overstepping	3 switch-offs in 30 sec.
Reset delay	
- Motor temperature static	5min ±1min
- Motor temperature dynamic	
1./24h	10min ±2min
2./24h	60min ±12min
3./24h	Locked
- Discharge gas temperature	
1.-5./24h	10min ±2min
6./24h	Locked
- Switching frequency overstepping	5min ±1min
- Oil differential pressure	90s ±18s
Resetting the lock or the reset delay	Main reset >5 sec. or reset by keyboard only possible if there is no error current
External button	
- Designed for	Potential-free normally open contact (typ. 5V, 1mA)
- Max. length connection line	1m
Relay	
- Contact	AC 240V 2.5A C300 at least AC/DC 24V 20mA
- Mechanical service life	Approx. 1 million switching cycles
Interface	Diagnose port (DP)
Protection class acc. to EN 60529	IP00
Connection type	Eye screw M10 (operating recognition), push-in spring terminals 0.25-0.75mm ²
Housing material	PA glass-fibre-reinforced
Mounting	Screw mounted
Dimensions	Refer to dimensions in mm
Weight	Approx. 200g
Check base	EN 61000-6-2, EN 61000-6-3 EN 61010-1 Overvoltage category II Pollution level 2
Approval	UL File No. E75899 cURus
Order data	22 A 495 S80
INT69 TML Diagnose	
Accessories and application information	see www.kriwan.com

Technical changes reserved