

INT250 Ex[®] Electrical part

INT250 Ex[®]



INT250 Ex

Application

Monitoring the lubrication system is especially important in refrigerant compressors.

KRIWAN's differential pressure monitoring is a very reliable method for piston compressors.

It consists of two parts; the INT250 Ex electrical part and a separately available screw-in part.

The electronic electrical part can be mounted or replaced without opening the refrigeration circuit.

This electrical part can be used in potentially explosive areas of zone 1 and zone 2. A corresponding zener barrier (see manufacturer test certificate) needs to be installed for the superordinate control or regulating unit.

Functional description

The difference between high pressure and suction pressure in the screw-in part influences a movable piston. Its position is registered without contact by the mounted INT250 Ex electrical part.

This information needs to be evaluated by a superordinate control or regulating system (PLC).

Installation instructions

1. Ensure cleanliness of the screw-in part.
2. Mount electrical part into the screw-in part. The cable outlet has to point downwards here.
3. Tighten the coupling ring hand tight.



The mounting, maintenance and operation are to be carried out by an electrician. The valid European and national standards for connecting electrical equipment have to be observed.

Avoid static charging.

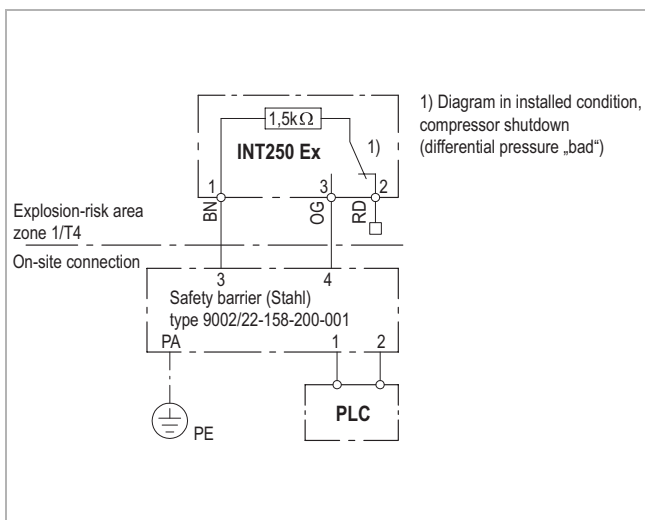

Wiring diagram

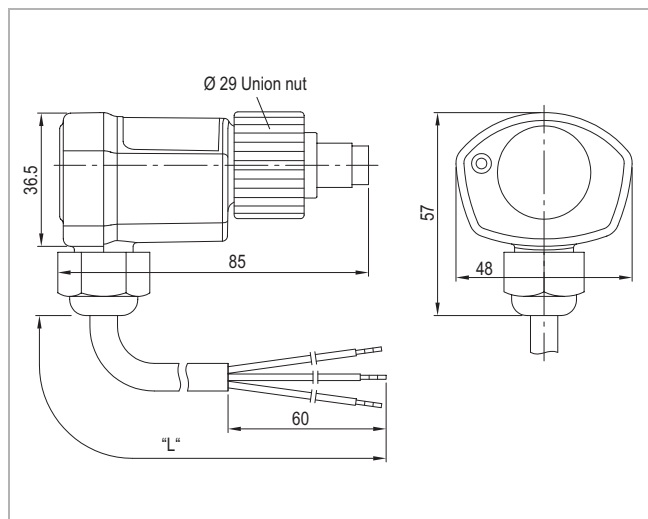

Dimensions in mm

Technical specifications

Permitted ambient temperature	-30...+90°C
Permitted rel. humidity	10-95% RH, without condensation
Switch output	
- Switching voltage	Max. AC/DC 50/60Hz 30V
- Switching current	Max. 30mA
- Mechanical service life	Approx. 10 million switching cycles
Protection class acc. to EN 60529	IP54 in mounted condition
Connection type	Cable 3xAWG-18 L=3m
Connection length	Max. 30m
Housing material	PA glass-fibre-reinforced
Mounting	Union nut (torque max. 10Nm)
Dimensions	Refer to dimensions in mm
Weight	Approx. 250g
Check base	EN 600079-0, EN 60079-11, EN 61000-6-2, EN 61000-6-3 EN 61010-1 Pollution level 2

Order data

INT250 Ex Electrical part	02 S 666 S32
Accessories and application information	see www.kriwan.com

Technical changes reserved