

DELTA-P® Screw-in part

DELTA-P®

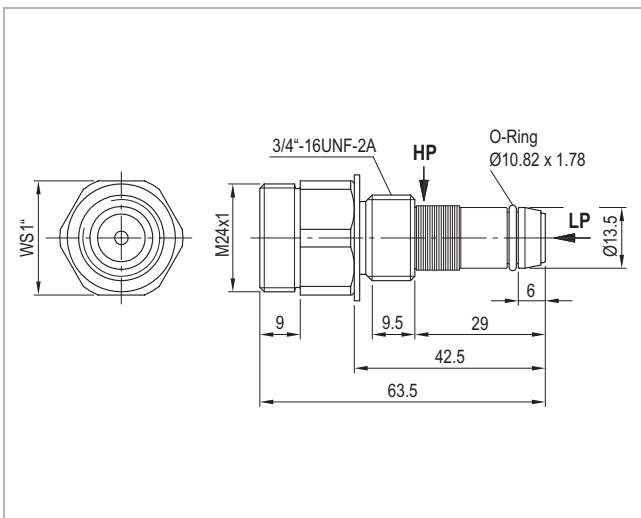

DELTA-P



Dimensions in mm

Application

Monitoring the lubrication system is especially important in refrigerant compressors.

KRIWAN's differential pressure monitoring is a very reliable method for piston compressors.

It consists of two parts: the screw-in part and a separately available evaluation circuitry.

The DELTA-P screw-in part is screwed directly into the pump housing, and is connected via internal channels to the suction and high pressure of the oil pump. This eliminates external pipe lines and flare connections.

The screw-in part does not need to be disassembled when mounting or exchanging the evaluation circuitry. The refrigeration circuit remains closed.

Functional description

The difference between high pressure and suction pressure influences the position of a movable piston. This is registered by the mounted evaluation circuitry.

Installation instructions

Montage: The maximum torque of the screw-in part is 90Nm and needs to be ensured by a ring spanner or a socket key. After installation, check for leaks.

A groove must be inserted on the compressor side to prevent the gasket from being pressed out.



Installation, maintenance and operation must be carried out by a specialist. The valid European and national standards for connecting refrigeration plants must be observed.

Technical specifications

Media temperature	-30...+90°C
Permissible relative humidity	10-95% RH without condensation
Operating pressure	Max. 140bar
Test pressure	210bar
Burst pressure	Min. 700bar
Permissible media	Non-corrosive media which does not attack the material. A test is recommended for individual cases.
Housing material	Brass
Differential pressure	0.65bar
Washer	20x26mm Cu
Weight	Approx. 100g

Order data

DELTA-P Screw-in part	02 D 442 S021
Accessories and application information	see www.kriwan.com